

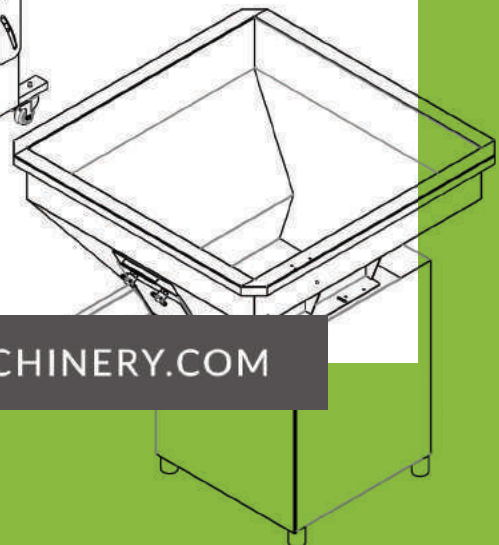

SEP
SEPTEMBER MACHINERY

PROFESSIONAL ON THE CONVEYORS

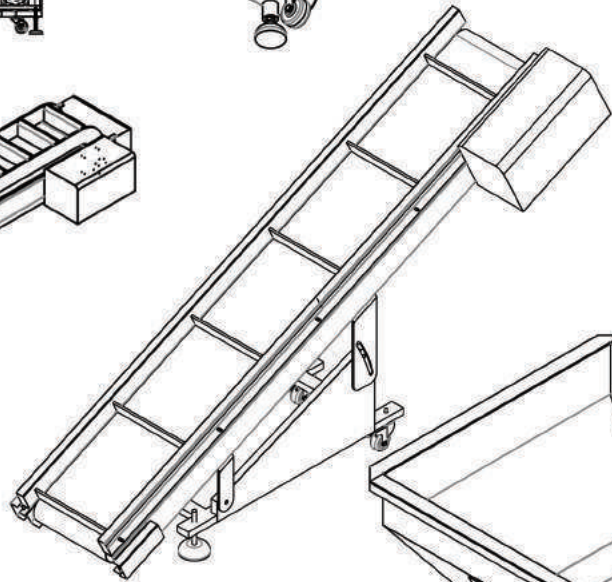
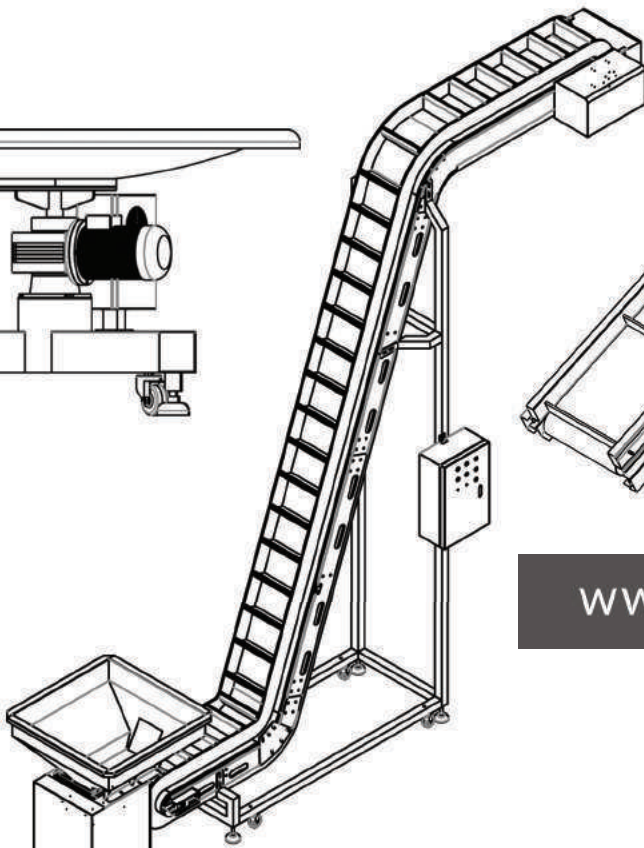
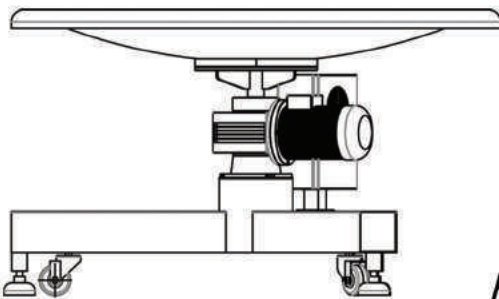
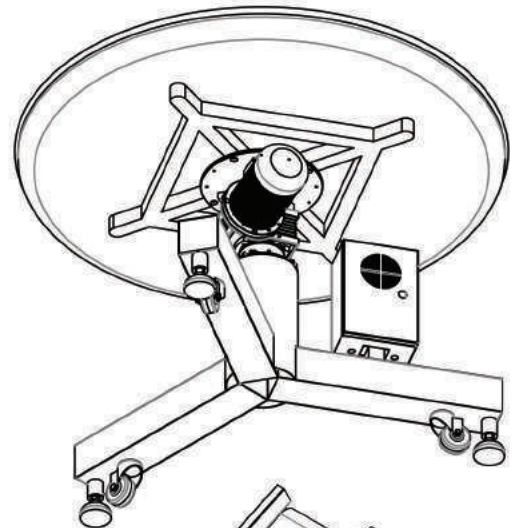
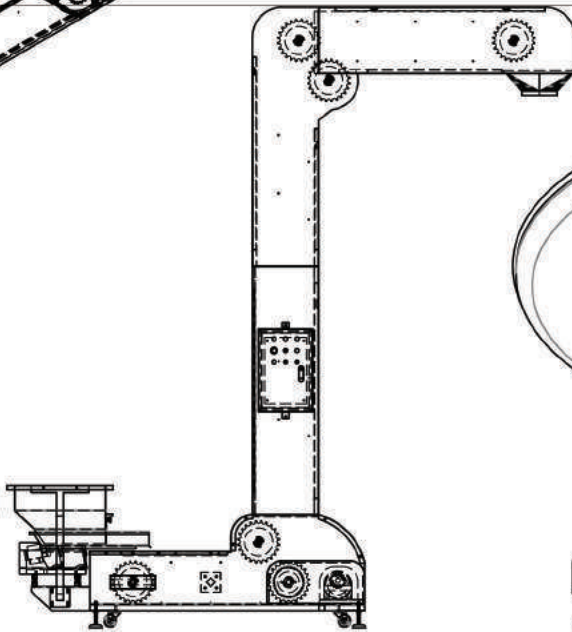
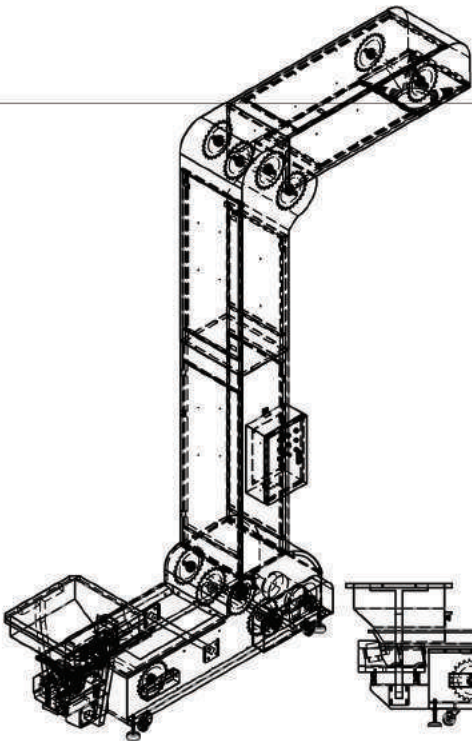

WWW.SEPMACHINERY.COM

BUCKET ELEVATOR

VERTICAL CONVEYING SOLUTION



1.8L



3.8L

WITH
VIBRATORY
FEEDER



NO
VIBRATORY
FEEDER



6.5L

These bucket elevators are ideal for most types of products as the buckets are capable of holding and transporting both dry and wet products as well as granules and powder. The bucket's contact surface food grade standard material.

APPLICATION

The bucket elevators are very well suited for a broad range of bulk products in the food, agriculture, pharmaceutical, cosmetic, chemical, ceramic, glass, recycling, building and metallurgical industries and others requiring gentle handling

SPECIFICATIONS

Bucket volume	1L	1.8L	3.8L	6.5L
No.s of discharge	single	single	one or multiple discharge outlets	one or multiple discharge outlets
Production capacity	1-3CBM/H	4-6CBM/H	6.5-8CBM/H	8.5-12CBM/H
Machine structure	stainless steel or painted steel			
Voltage	Three phase 380V or single phase 220V, 50HZ/60HZ			
Power supply	0.75KW	0.75KW	1.5KW	2KW

Available in almost any sizes, we can build a bucket elevator to your exact specification.





C TYPE



CARBON STEEL TYPE



MULTIPLE DISCHARGE OUTLETS



LONG FEEDING



STEEL BUCKET TYPE



SINGLE BUCKET

ADVANTAGE

- Gently convey your product without damage
- Compact footprint for space saving benefits
- Suitable for abrasive products
- Flexible and modular system
- Energy saving compared to chain/screws/others
- Easy to clean
- Simple maintenance

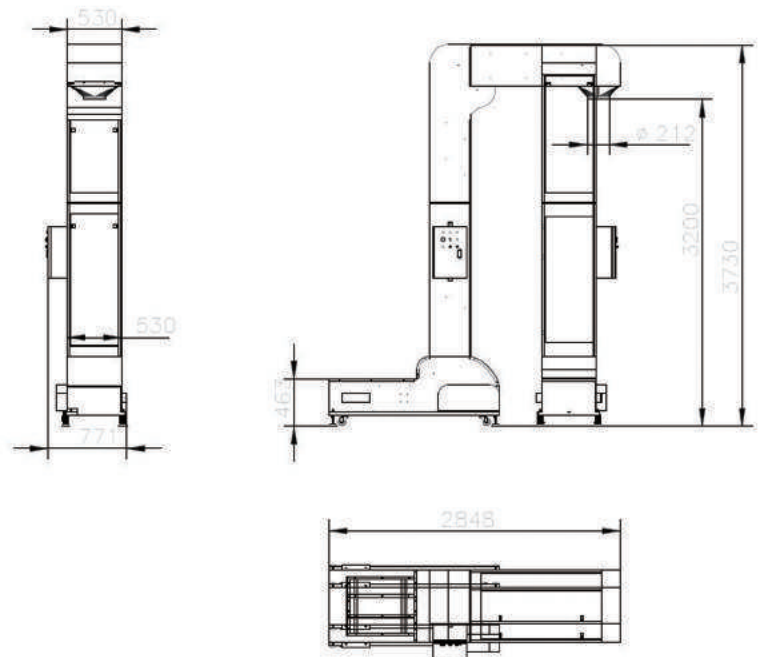

BELT CONVEYOR

VERTICAL CONVEYING SOLUTION



Today there are different types of belt conveyor that have been created for conveying different kinds of material available in PVC, PU, rubber or other materials.

SPECIFICATIONS

Fram material:	Carbon steel or stainless steel
Belt material	PP, PVC, PU or stainless steel
Production capacity	1-3CBM/H (for belt width 300mm) depend on the actual situabtion
Voltage	Three phase 380V or single phase 220V, 50HZ/60HZ
Power supply	0.75KW

**can be special made according to your requirments*

Available in almost any sizes, we can build a belt conveyor to your exact specification.

APPLICATION

The Belt Conveyors are very well suited for a broad range of bulk products in the food, agriculture, pharmaceutical, cosmetic, chemical, ceramic, glass, recycling, building and metallurgical industries and others requiring gentle handling





CORRUGATED BELT



TURNING TYPE



STAINLESS STEEL MESH BELT



HORIZONTAL TYPE



BOWL TYPE



STAINLESS STEEL BUCKET TYPE

ADVANTAGE

- Easy to clean, can withstand steam cleaning.
- Simple maintenance and 'strong build' as standard.
- Mild steel, 304 and 316 stainless steel or plastic options.
- Food quality belts available and designed with hygiene in mind.
- Additional items can be added (hoppers, filtering, visual examination/rejection etc).

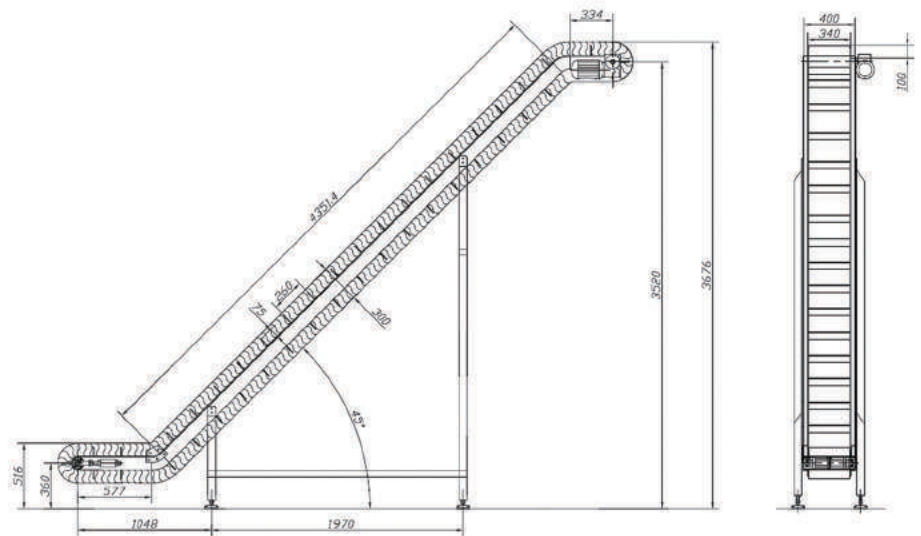

SCREW CONVEYOR

POWDER CONVEYING SOLUTION



A screw conveyor or auger conveyor is a mechanism that uses a rotating helical screw blade, called a “flighting”, usually within a tube, to move powder or granular materials, such as flour, seasoning etc.

SPECIFICATIONS

Model	SEP-S1	SEP-S5	SEP-S7	SEP-S8	SEP-S10
Capacity	1-4CBM/H	5-6CBM/H	7-8CBM	8-9CBM/H	10-12CBM/H
Pipe Diameter	114mm	141mm	159mm	168mm	219mm
Power Supply	1.5kw	2.2kw	2.2kw	3kw	4kw
Hopper Volume (Standard)	200L	200L	200L	200L	200L
Voltage	3 Phase 380v 50-60HZ				
Angle of incline	45 degree for standard, it can customized for 30 or 60 degrees				
Discharge Height	2200mm for standard, others are available, the max height is 6.5M				
Weight	150	180	230	260	295
Hopper Type	Rectangle or Round				

Available in many sizes, we can build a screw conveyor to your exact specification.

FASTBACK HORIZONTAL MOTION CONVEYOR

FRAGILE PRODUCTS CONVEYING SOLUTION

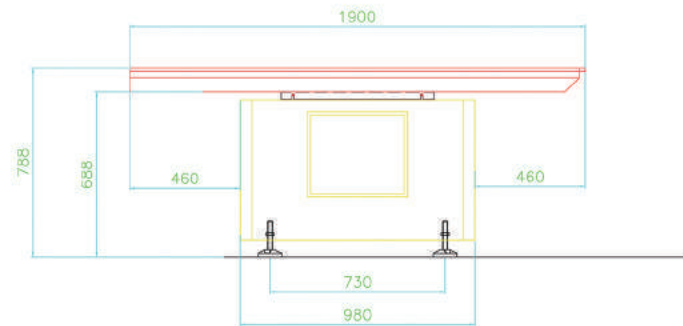
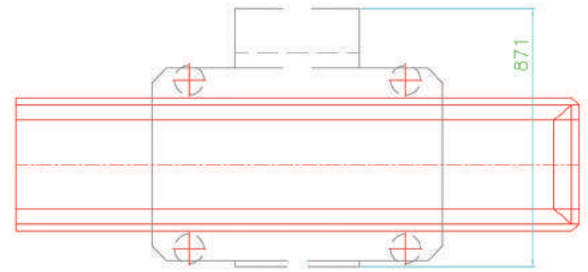
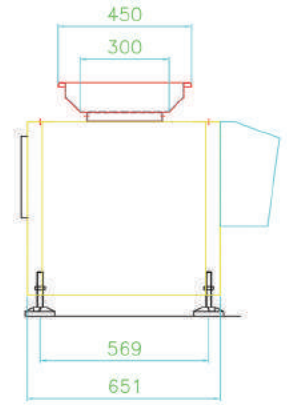

The fastback horizontal motion conveyors are ideal for most types of products especially for the fragile products, such as potato chips, puffed food as well as granules.

APPLICATION

The fastback horizontal motion conveyors mainly uses for carrying candy, potato chips, puffed food etc.

SPECIFICATIONS

Material	304# stainless steel
Infeed pan length	1900mm
Infeed pan width	300mm
Production capacity	Adjustable
Machine weight	300KG
Voltage	Three phase 380V-50HZ
Power	1.5 KW
Option	water-proof motor
<i>*can build the outlets with pneumatic control</i>	

Available in many sizes, we can build to your exact specification.



VIBRATORY FEEDER

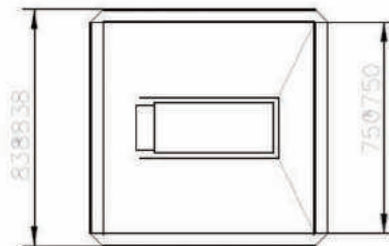
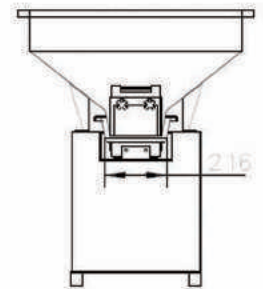
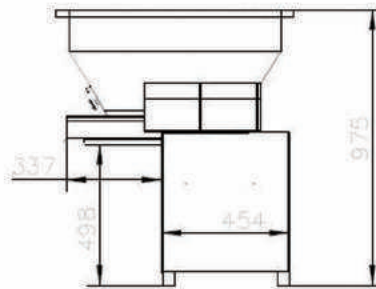
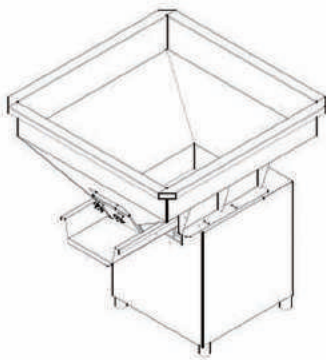

A vibratory feeder is an instrument that uses vibration to "feed" material to a process or machine.

They are mainly used to transport a large number of smaller objects to the belt conveyor, bucket elevator, Multi-head Weigher etc.

SPECIFICATIONS

Hopper Volume	165L
Production capacity	3-7M3/H
Speed/ vibration adjustable	Yes
Voltage	Single phase AC 220V-50HZ/60HZ
MAchine weight	150KGS
Machine Packed Dimension	1350mm(L)*1000mm(W)*1400mm(H)

Available in almost any size, we can build to your exact specification. For the standard sizes, please check the layout above.

WEIGHER SUPPORT PLATFORM

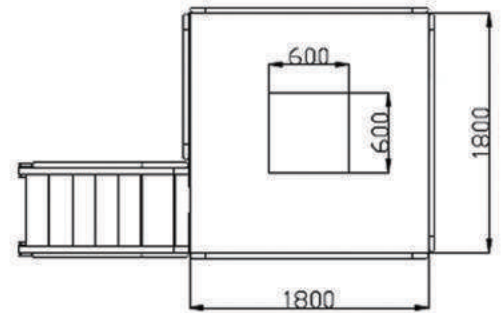
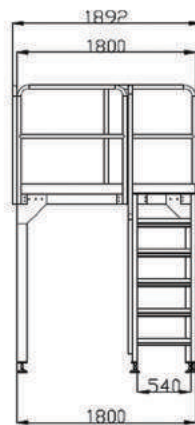
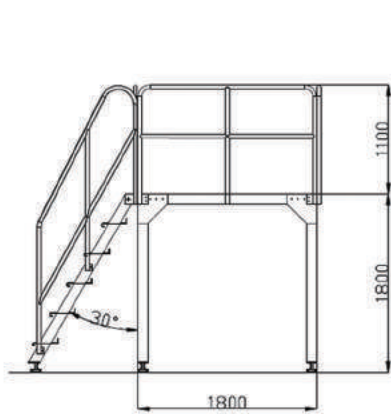
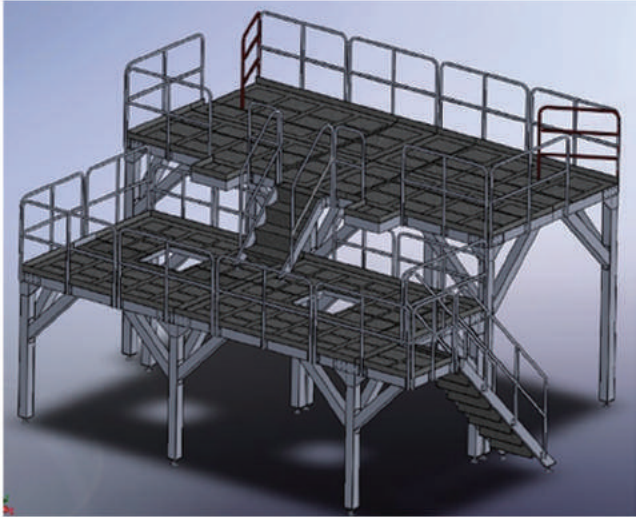

Customizable heavy-duty Support Platform for mounting Multihead and Linear Weighers on. Heights and sizes can be custom built to suit the situation. Can be supplied in painted or stainless steel versions

Available in almost any size, we can build a platform to your exact specification. For the standard sizes, check the above layout.

SPECIFICATIONS

Material	304# stainless steel with Aluminum
Sizes	1800 x 1800 x 1800mm
Options	Painted steel or stainless steel surface and stairs

**The sizes can be special made as per requirements*

TAKE-AWAY CONVEYORS

The Take away conveyor are built from stainless steel and equipped with modular flight belts(PP), PU or PVC to remove finished bags from your fill seal machine and elevate them to the check system or Pack Off Table, then manually removed elsewhere. The Take-away conveyors and pack-off tables will deliver in a whole set, no need to install and it's only asking for maintenance once a month.



PP Belt



Adjustable Angle



PU Belt

TAKE AWAY CONVEYOR DESCRIPTION

- Standard belt width : 253mm
- Standard belt type: PP, PVC and PU
- Angle adjustable as option
- Non-slip PVC belt available
- Can Add casters (with brake function) for easy moving

SPECIFICATIONS

Model	Finished product conveyor
Transportation speed	15M/min (Speed adjustable)
Machine packaged dimension	1800(L)x520(W)x1300mm(H)
Voltage	Three phase 380V/single phase 220V
Power consumption	180W

Available in almost any size, we can build to your exact specification. For the standard sizes, check the layout at the below.

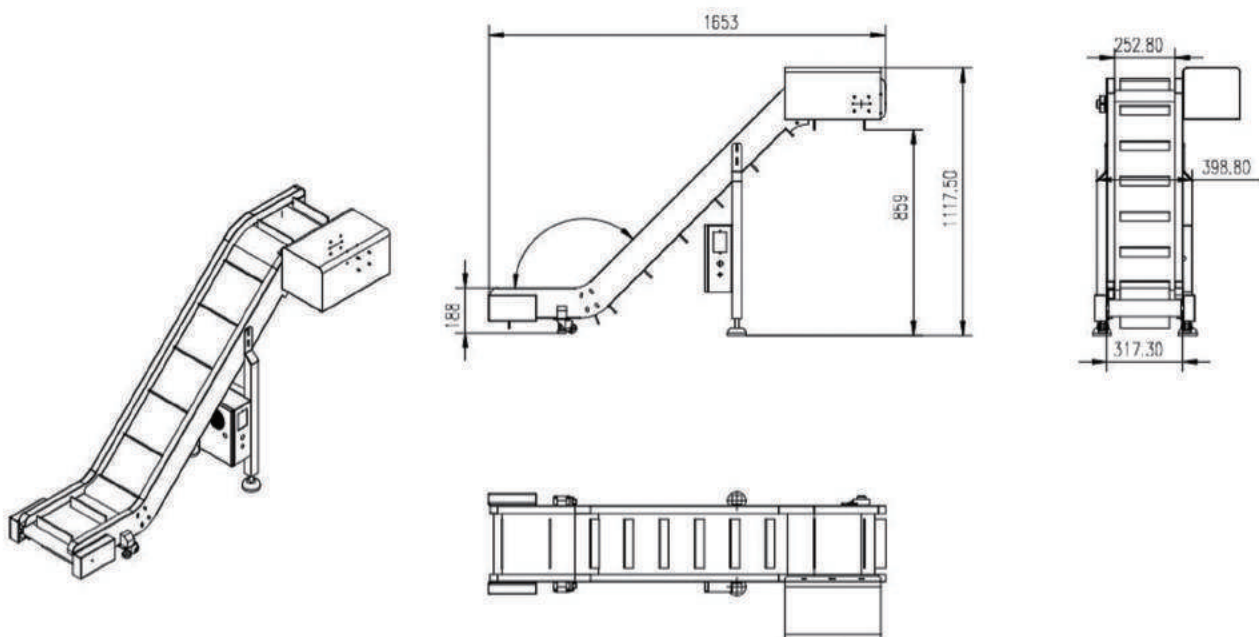

PACK-OFF TABLES

The turntable is for taking the goods from the finished conveyor and waiting for the next operation.



TURN TABLE DESCRIPTION

- Table diameter: 1.2m, 1m, 1.5m
- Tabel material: 3mm thickness stainless steel
- Table type: falt, curved
- Can Add casters (with brake function) for easy moving
- Fast delivery, can be ready in 15 working days

SPECIFICATIONS

Material	fully #304 Stainless Steel
Production Capacity	Speed adjustable
Pan diameter	1200mm (standard) other sizes are available
Discharge height	800mm
Power/Voltage	0.37KW / 3 ph 380V 50HZ/60HZ
Packing detail	Ship by whole machine, no need to install
Option	1000mm, 1500mm diameter pan available

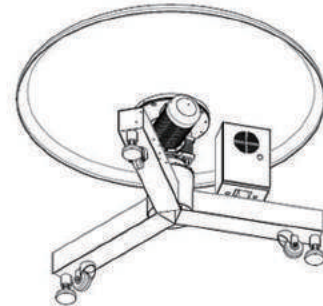
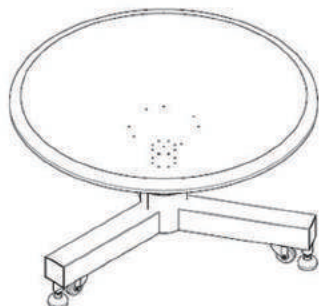
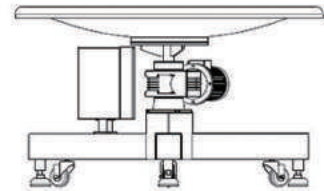
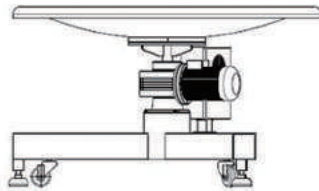
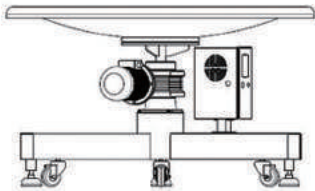

COMPANY INTRODUCES

We're a stable and steadily growing company, which is a professional partner for many prestigious companies throughout the world. We deliver high-tech, individual, efficient, reliable and versatile solutions that answer current and future requests from the market.

Our products including **bucket elevator, belt conveyor, screw conveyor, platform, fastback horizontal motion conveyor, vibratory feeder, take away conveyor** and **rotary table**.

We can provide what big corporations cannot, a personal experience. Our customers deserve the attention that most competitors can't give, which is time. The time to answer a phone call for technological issues. We believe having a small and exuberant team gives us an advantage in aiding our customers growing businesses.

Our business provides a stepping stone for advancing in your industry with better production and quality equipment. Relationship with our customers does not end once the transaction is made. It continues to develop even after the machine is on and ready for production.

WECHAT

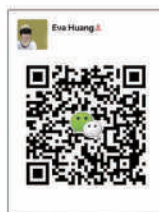

INFO@SEPMACHINERY.COM

(WHATSAPP) +86 13794043967

EVAHUANGCHINA

WWW.SEPMACHINERY.COM

#35 KEJI EAST ROAD, LUNJIAO TOWN, SHUNDE,

FOSHAN CITY, GUANGDONG PROVINCE, CHINA 528308

